

SIDE MOUNTING LETTERBOX ASSEMBLY

1. Slide *Leg Tie Bolt (C)* into *Slotted Letterbox Stand (B)* and screw into *Base Plate (A)*.
2. Slide *Newspaper Holder (J)*, *Number Plate (K)* and *Side Mounting Bracket (G)* into slots on *Slotted Letterbox Stand (B)*. Adjust to suitable height and tighten locking screws.
3. Fit *Top Plate (D)* and secure with *Nut (E)* on top thread of *Leg Tie Bolt (C)*. Tighten.
4. Screw *Top Ball (F)* on top of thread and hand tighten.
5. Fit *Letterbox *(I)* on screw (*H*) on *Side Mounting Bracket (G)* and fasten with *Nut (E)* supplied.

*Letterbox type is representation only to illustrate the mounting, does not necessarily indicate the design of the letterbox you have purchased

(THIS LETTERBOX CAN BE FIXED TO EXISTING CONCRETE PAD BY DYNA BOLTING THROUGH HOLES IN *BASE PLATE (A)* OR CONCRETED INTO THE GROUND BY UTILISING THE "U" BOLT THAT COMES WITH THE *BASE PLATE*)

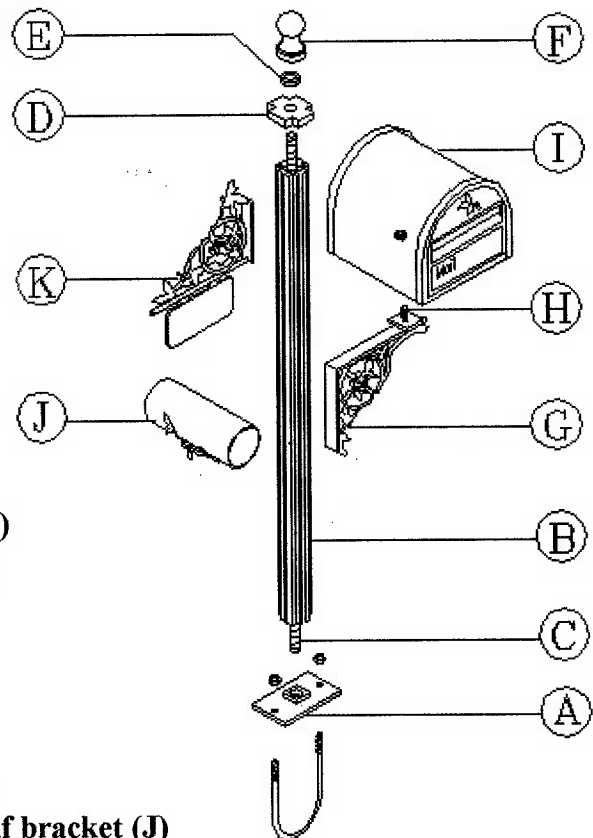

The following components should be contained in TWO cartons for this letterbox:

Carton A Base Plate with "U" Bolt (A)
 Slotted Letterbox Stand (B)
 Leg Tie Bolt with Nut (C)
 Top Plate (D)
 Top Ball with Nut (F)

Carton B Letterbox (I)
 Side Mounting Bracket (G)
 Newspaper Holder with Leaf bracket (J)
 Number Plate (K)